

# IN-LINE SAMPLING



reliable sampling solutions

## Versatile In-Line Sampling

The IL50 Sampler provides a versatile and low cost means of automated sampling. Powered by a Pneumatic Cylinder the sample collector enters the product and collects a sample. The sample collector then returns and empties the product through the outlet spout below.

# IL50

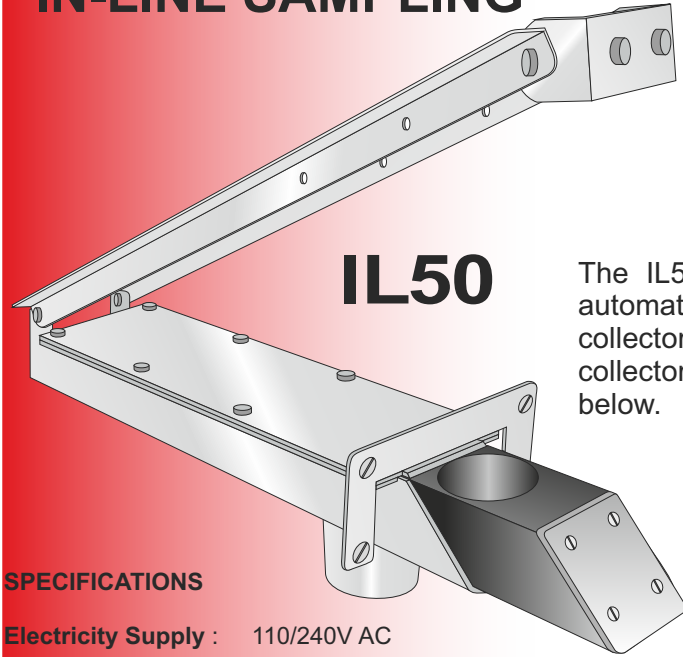

### SPECIFICATIONS

Electricity Supply :	110/240V AC
Air Supply :	6.0 - 7.0 Bar
Sample Collector :	60 Dia x 60 Depth (mm)
Volume:	172 cm <sup>3</sup>
Installation :	Easy to install, bolt on fixing for square or round ducts *
Maintenance :	None
Construction :	304 Grade Stainless Steel
IP Rating:	IP65
Dimensions :	

Capable of sampling from free flowing products.

Operates from compressed air, controlled by 24volt DC electrics.

Will sample a varied range of products from free flowing grains / cereals to pellets up to 20mm dia.

Programmable via Control Unit

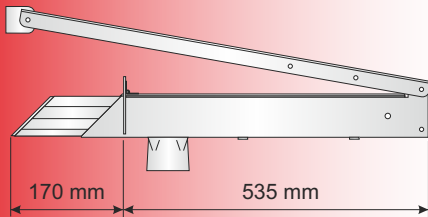

### Advantages of automating the practice of sampling by using the IL50

1. Repeatable sampling is guaranteed.
2. The same volume of sample is taken to enable accurate comparison of results.
3. Reduction in labour input = reduction in human error.
4. Minimisation of Health and Safety risks associated with manual sampling.
5. Sample can be collected via a gravity feed flexible pipe.

Complies with Council Directive 2006/95/EEC for Low Voltage Directive.

\* Round ducts must have a minimum radius of 1 metre otherwise duct adapters are available upon request.

Full Specification available at

Web: [www.tekpro.com](http://www.tekpro.com)

Email : [info@tekpro.com](mailto:info@tekpro.com)

Tel : +44 (0) 1692 403403

Fax : +44 (0) 1692 404955

TekPro Limited - Willow Park - North Walsham - Norfolk - NR28 0BD - UK



We reserve the right to alter these specifications without prior written notice.

TEK/SALES/ADVERTISING/ENGLISH/CORELVERSION/6382/02.11.11/02/AN

# IN-LINE SAMPLING



reliable sampling solutions

## Versatile In-Line Sampling

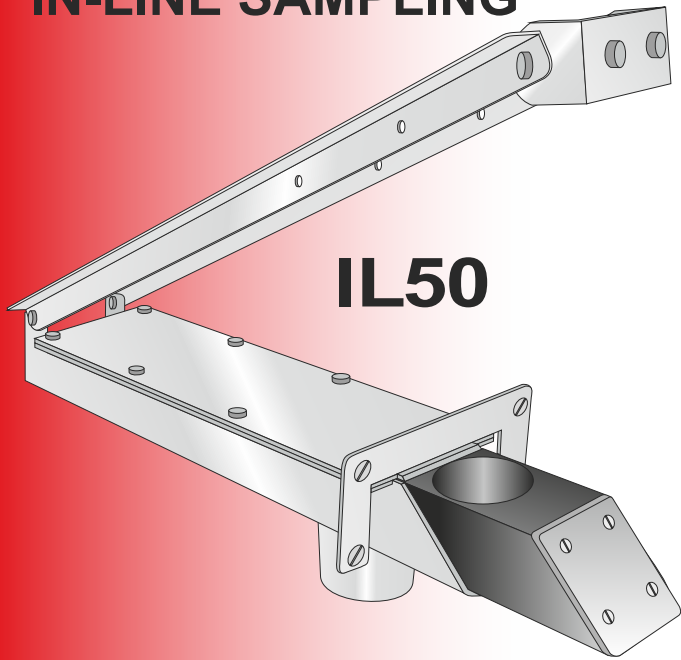

### IL50

The hinged adjustable mounting bracket allows for installation not only into vertical ducts but ducts angled up to 45°.

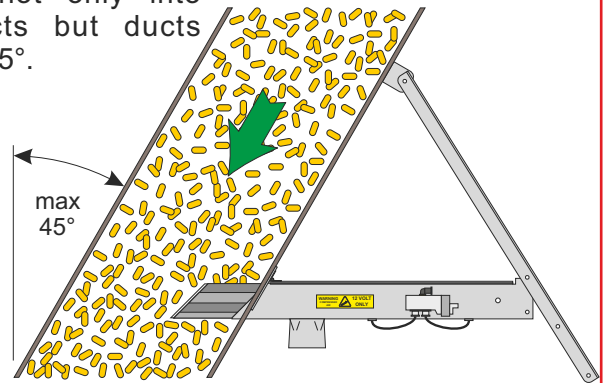

Powered by compressed air, the IL50 sample collector enters the material flow and catches a sample.

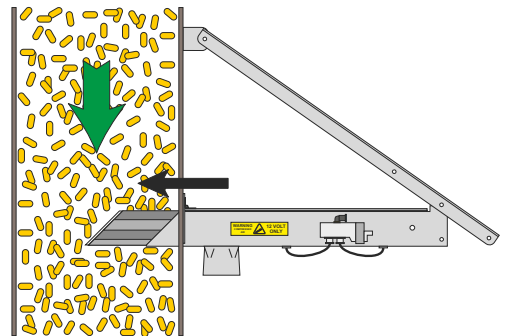

The sample collector then returns, emptying the sample through the chute below.

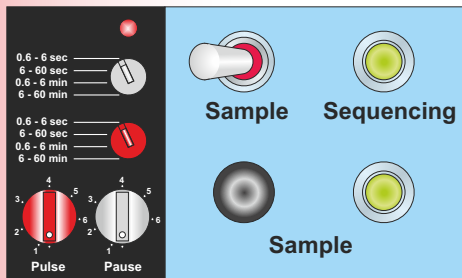
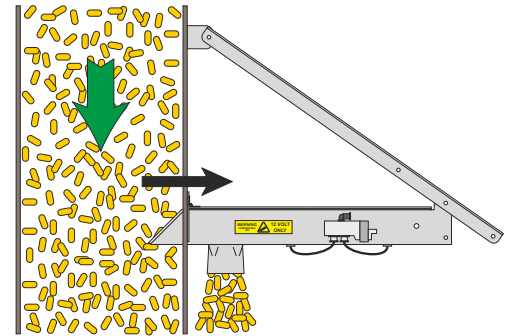

### Control :

Programmable Timer Unit with manual single sample operation and fully automatic sequence timer.

Time between samples is variable from 6 seconds to 60 minutes.

Time in product (sampling time) is variable from 6 seconds to 60 minutes.

The Control Unit has the ability to be interfaced with existing mill control systems.

Complies with Council Directive 2006/95/EEC for Low Voltage Directive.

Full Specification available at

Web: [www.tekpro.com](http://www.tekpro.com)

Email : [info@tekpro.com](mailto:info@tekpro.com)

Tel : +44 (0) 1692 403403

Fax : +44 (0) 1692 404955

TekPro Limited - Willow Park - North Walsham - Norfolk - NR28 0BD - UK

